

1

2

3

4

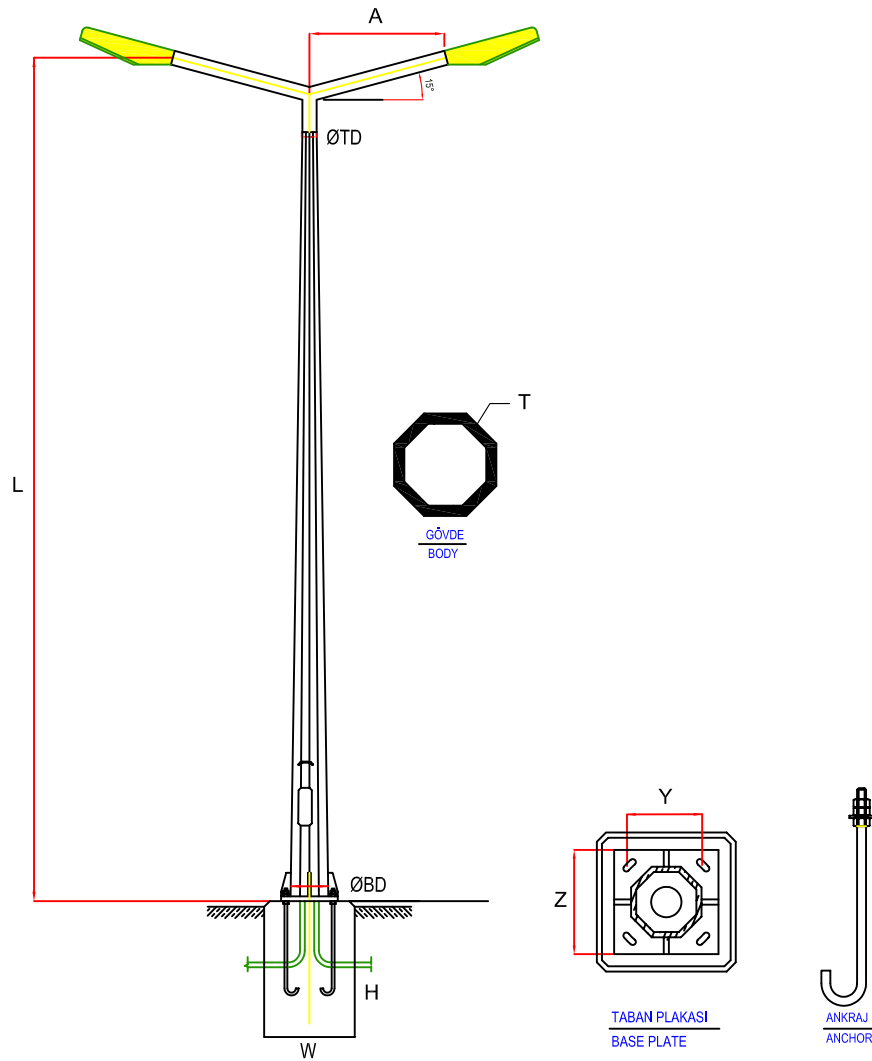

All values are given only information.

Tower high (m) L	Drawing no	Bracket length (mm) A	Top Dia. (mm) TD	Bottom Dia. (mm) BD	Body thick. (mm) T	Base Plate. (mm) Y x Z	Anchor (mm)	Foundation (mm) WxH	Total Weight (kg)
6	FRG / LP2.60-10	500-2500	Ø60	Ø115	3	180 x 250	4 x M16	500 x 900	61
7	FRG / LP2.70-10	500-2500	Ø60	Ø128	3	180 x 250	4 x M16	600 x 1000	71
8	FRG / LP2.80-10	500-2500	Ø60	Ø135	3	180 x 250	4 x M16	600 x 1000	81
9	FRG / LP2.90-10	500-2500	Ø60	Ø152	3	200 x 300	4 x M16	700 x 1100	92
10	FRG / LP2.100-10	500-2500	Ø60	Ø160	3	200 x 300	4 x M16	700 x 1200	110
11	FRG / LP2.110-10	500-2500	Ø60	Ø174	3	300 x 400	4 x M20	800 x 1200	123
12	FRG / LP2.120-10	500-2500	Ø60	Ø205	3	300 x 400	4 x M20	800 x 1200	150
13	FRG / LP2.130-10	500-2500	Ø60	Ø235	3	300 x 400	4 x M20	1100 x 1400	189
15	FRG / LP2.140-10	500-2500	Ø60	Ø260	3	300 x 400	4 x M24	1100 x 1400	228



FARALYA GROUP

Steel Const.and Trade Corp

www.faralyagroup.com

info@faralyagroup.com



contract no:

customer:

drawing name:

DOUBLE BRACKET OCTOGONAL SECTION
STREET LIGHTING POLES

drawing no: FRG / LP2

REV. 0

1/1 page

rev.no description date name

weight

scale